

A - A

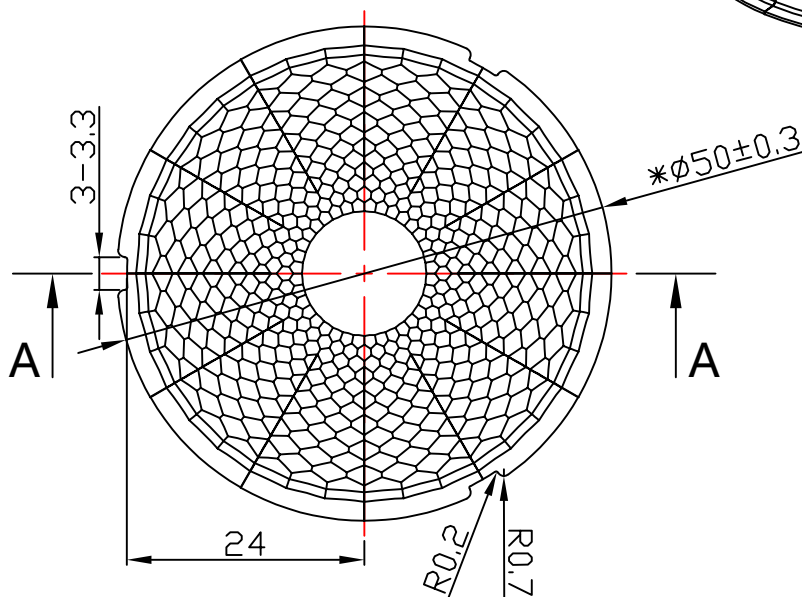

Light Source	LUMILEDS 1203
PlasticHolder	92.70.410.00
Metal Adaptor	
Design Angle	$17^\circ \pm 3^\circ$
Measured Angle	$17.6^\circ$
Efficiency	$\geq 95\%$

光学装配示意图

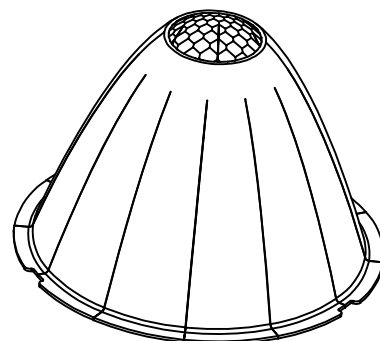
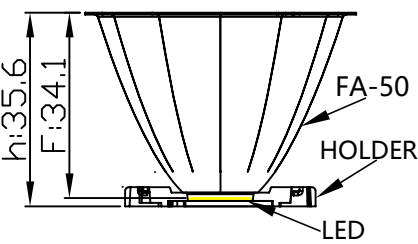

Technical requirements:

- 1.MATERIAL: T=0.4mm High reflectivity aluminum(Mirror surface).
- 2.\*\*KEY CONTROL DIMENSION.
- 3.Tolerances not noted are in accordance with the tolerance table.
- 4.unmarked rounded corners Press for 3D.
- 5.Surface without imprint, black spots, cracks, wrinkles and other poor.

标记 MARK	处数 NO.OF MODIF	更改内容 MODIFICATIONS	签名 SIGNED BY	更改日期 MODIF. DATE
设计 DESIGNER	制图 DRAWN BY	比例 SCALE	1:1	
工艺 TECHNICAN	审核 CHECKED BY	视角 1st ANGLE PROJECTION		
批准 APPROVED BY	日期 DATE(DD-MM-YYYY)	页数 PAGE	SHEET 1 OF 1	

DIMENSION TOLERANCE TABLE (UNLESS OTHERWISE STATED)						
> 0-5	> 5-30	> 30-90	> 90-150	> 150-250	> 250-400	> 400-700
$\pm 0.15$	$\pm 0.2$	$\pm 0.4$	$\pm 0.5$	$\pm 0.8$	$\pm 1.5$	$\pm 2$
PUNCH TOLERANCE TABLE (UNLESS OTHERWISE STATED) (ANGLE)						
> 0-10	> 10-50	> 50-120	> 120-250	> 250-360		
$\pm 1^\circ$	$\pm 0.5^\circ$	$\pm 0.3^\circ$	$\pm 0.2^\circ$	$\pm 0.166^\circ$		
产品图 PRODUCT DRAWING						单位 UNIT mm

		版本 VERSIONS K
		产品编码 PRODUCT CODE 91.01.1298.000
产品名称 PRODUCT NAME 1-1298-L		客户代号 CUSTOMER ID NT
客户编号 CUSTOMER CODE FA-50-17D		